



**KOREA GLOBAL SERVICE**

# Korea Global Service

Korea Integrated Ship Maintenance Service

KOREA GLOBAL SERVICE CO., LTD.  
Tel : +82 52 710 5006  
E-mail : sales@koglos.com

# One Stop Total Maintenance Service

## Specialized LNG ship dock maintenance service

- HV Switchboard by ex-Hyundai commissioning engineer
- Generator by ex-Hyundai engineer
- DF Engine Mechanical Overhaul by ex-Wartsila service engineer

## Over 25 years work experiences in Hyundai warranty service

- Engine, Ship & Machinery service experiences in Hyundai Heavy Ind.
- Ex-Hyundai commissioning engineers to be arranged

## Qualified service engineers arranged

- Hyundai cooperative electrical service company
- Authorized service companies by Hyundai, Doosan & STX

## Competitive service price provided

- Lump-sum man-day price including 3 hours overtime
- No overtime charges other than lump-sum price
- Genuine Hyundai parts or maker's OEM parts

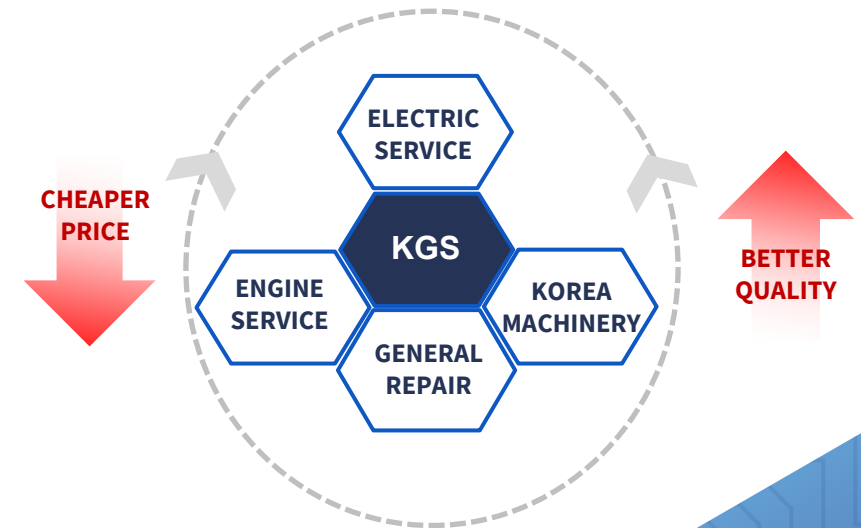





# 1. Electrical Maintenance Service

Switchboard, Generator, Retrofit, Control

# Electric Equipment SWBD Dock Maintenance

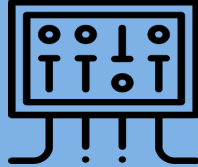
With the experiences of more than 20 years worked for Hyundai, Korea Global Service can provide professional & suitable technical supports to the clients. We are proud of offering an appropriate & swift solution derives from extensive/various work experiences of our engineers to satisfy customer's requirements.

 <p><b>HV SWBD</b>          Protection Relay          VCB Inspection &amp; Test          Vacuum &amp; Operation Test          Under, Overcurrent &amp; Voltage          Bus Bar &amp; Isolator Cleaning</p>	 <p><b>LV SWBD</b>          LVSB Internal Check          ACB Safety Device Test          ACB Overhaul          ESBDC Circuit Check</p>	 <p><b>Miscellaneous</b>          Generator Overhaling          Nabtesco Maintenance          Battery Charger Check          Replacing Contactor &amp; Relay</p>	 <p><b>Onboard Test</b>          Shutdown &amp; Black-out Test          AMS &amp; BMS power unit Test          E/R Pump auto stand-by Test</p>
--	---	---	---

 **HYUNDAI ELECTRIC**

**ABB**

**JRCS**

 **General Electric**

**Schneider Electric**

**SIEMENS**

**Service covers to major makers  
(Switchboard, ACB, VCB, Protection relay)**

## ◆ Example of Service Arrangement (LNG Carrier, Dry-dock)

- Engineer : 4 S/E • Working Period : 7 ~ 8 days
- HV/LV Switch Board Interlock & Cleaning
- Protection Relay, VCB, ACB Overhaul & Test
- On-board test : Shutdown & Trip/ Battery Charger/ Black Out Test



# Electric Equipment SWBD Dock Maintenance



# Generator & Motor Maintenance Service

## Generator Service

KGS has the well experienced **ex-Hyundai engineers for generators**

- Frame - Main T/Box, Air cooler, Leakage detector, temperature sensors
- AVR – AVR assembly, Cable connection
- Insulation Resistance – Main stator, Main rotor, Exciter, Space heater
- Mech. Check – Between Main stator and rotor, Between shaft and bearing
- Running test – Check noise, voltage at no-load & step load

## Motor Service

- Insulation Resistance – main stator winding, space heater
- Terminal box – Power cable, Heater cable, Bolt tightening
- Bearing – Bearing temp sensor, Grease injection pipes

**Spares for Hyundai generator & motor can be supplied**

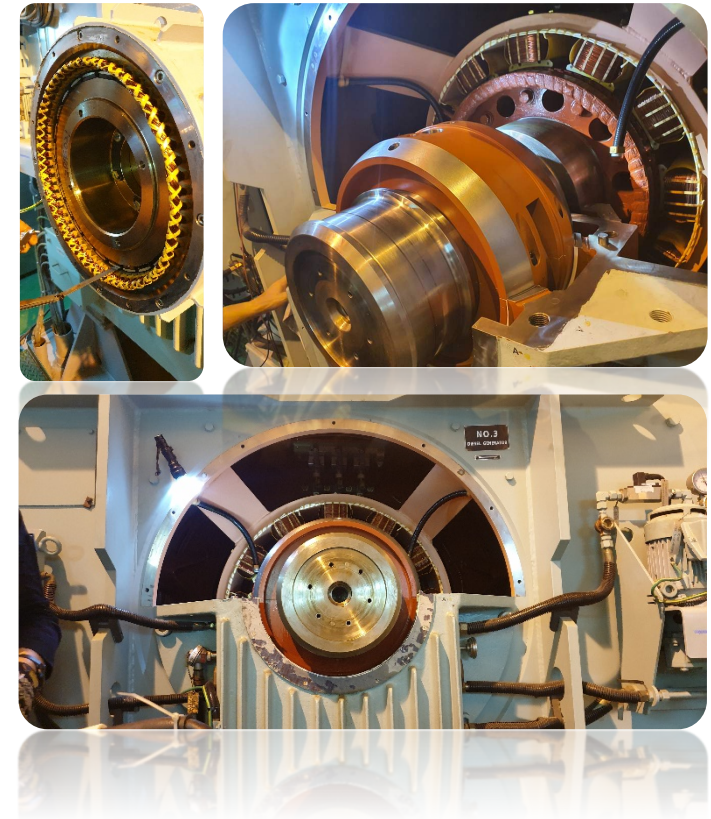



# Modification & Retrofit Service

## ACB Retrofit service(Old ACB to HGN Type)

KGS has lunched retrofit service of HiAN to HGN type, without changing bus-bars within a day. This retrofit service extends to other maker's ACB, such as ABB, Terasaki & Schneider.

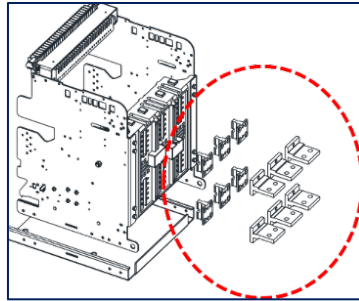

## HiMAP (M, F, FI) Reconditioning

KGS team provides reconditioning service for HiMAP M, F & FI and supplying spares with competitive price. SYMAP-BC/BCG complete: KGS provide competitive price which is equivalent to HiMAP-BC/BCG.

- ◆ Re-conditioning service is only for HiMAP-M, T & FI, **not applicable to HiMAP-BC/BCG**
- ◆ Service to be conducted at KGS workshop, Korea
- ◆ Ex-Hyundai commissioning engineer to be arranged

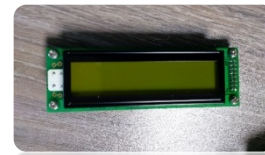

## Modification & Retrofit Service

### Arc Flash Protection Retrofit

KGS carried out retrofit of Low Voltage Switchboard for QGTC & Shell LNG vessels. By technical cooperation with ABB, KGS has completed project 8 vessels successfully. This retrofit prevents any possible fire accident derived from arc flash inside panel.

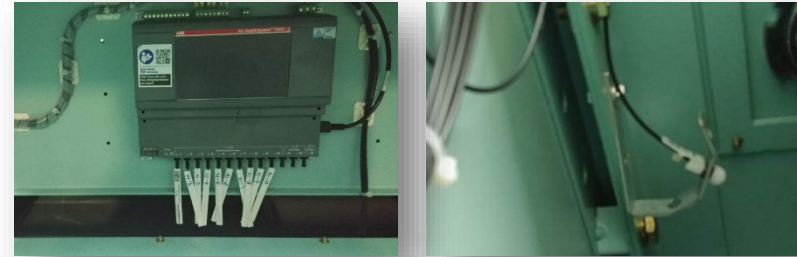

### UPS Retrofit

KGS experienced lots of UPS retrofit with various types.

Rating: 5~300KVA, Input: AC400/415/440/690V, Output: 200~240V 1Ø

Options: Ingress protection up to IP44, Battery management system

Including: Class approval for DWG





## Modification & Retrofit Service

### AMP(Alternative Maritime Power)

From 2014, all vessels which call to California should reduced generator power and use shore power based power. The rule changed more strictly and penetrator power should reduced by 80% from 2020. KGS team has experienced for installation of AMP system with spares of Cavotec.

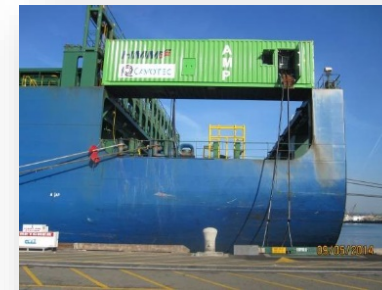
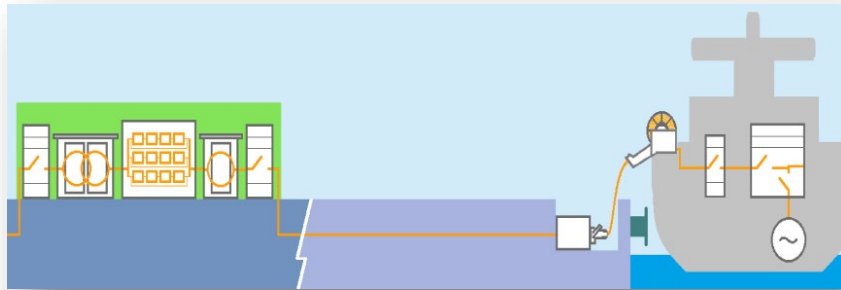

### Switchboard Modifications

KGS provides service for old switchboard modification cooperated with Korean major switchboard manufacturer. Our service is not only modification/manufacturing but design also available.

- Low voltage switchboard refurbishments
- Air circuit breaker upgrade and replacement
- Bus bar modifications



# Control System (Nabtesco, ACONIS)

Korea Global Service has special team who has various field experiences in original maker for more than 15 years for system commissioning at Shipyard or warranty manager to rectify troubles at field. We assure you that we can provide reasonable solutions by using abundant experiences.

## Nabtesco

### Governor Control System

- Governor Control Panel, Actuator
- Governor Junction Box, Pick up sensor
- 1 S/E x 1 day

### M/E Remote Control system

- Bridge Indication Panel, Engine side Panel
- Bridge terminal board unit
- Telegraph Transmitter & logger
- Control Panel, Power source, pick up sensor
- 1 S/E x 3 days

#### Service Man Day rate USD 1,200

- 8 hours + 3 overtime per days
- No overtime charge
- Same price in holiday works
- 30% cheaper than original maker

## ACONIS

### AMS, PMS

- Aconis-1000/2000/2000E/DS & 1000 PMS/2000 PMS
- Inspection full function and optimize system
- 1 S/E x 1 day

### BNWAS

- HIWMS / HiWMS-PE
- Inspection full function and modify function
- 1 S/E x 1 day

#### Service Man Day rate USD 1,300

- 8 hours + 3 overtime per days
- No overtime charge
- Same price in holiday works
- 30% cheaper than original maker

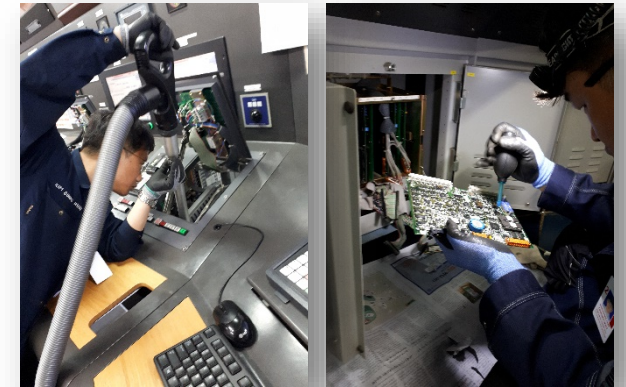

# KGS ACONIS Dock Retrofit & Maintenance

All engineers are ex-ACONIS employees as designer and field engineer, more than 30% cost effective than the original maker. Company registered to Hyundai Global Service(HGS) as the authorized service agent.

## 1) BWTS, Scrubber ACONIS Modification: 1 S/E x 2 days for each

BWTS
<ul style="list-style-type: none"> <li>• Add Power request &amp; PMS function</li> <li>• Add DI Point on AMS                             <ul style="list-style-type: none"> <li>• BWTS Running</li> <li>• BWTS Shut Down</li> <li>• BTWS Common Alarm</li> </ul> </li> <li>• AMS Display Modification                             <ul style="list-style-type: none"> <li>• Add Piping Overview</li> <li>• Add V/V Symbol for BWTS</li> </ul> </li> </ul>

Scrubber
<ul style="list-style-type: none"> <li>• Add Power request &amp; PMS function</li> <li>• Add PMS interface</li> <li>• Add EGCS interface                             <ul style="list-style-type: none"> <li>• M/E &amp; G/E running signal</li> <li>• M/E RPM &amp; G/E Load(Kwh)</li> </ul> </li> <li>• Add DI Point on AMS                             <ul style="list-style-type: none"> <li>• EGCS Running/ Shut down</li> <li>• EGCS common Alarm</li> </ul> </li> </ul>

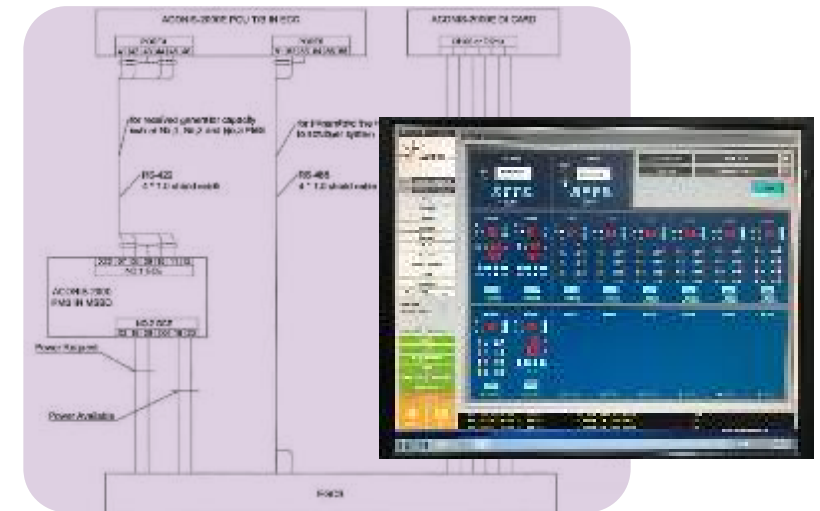

**Scrubber ACONIS Modification Overview**

**Service Cost: \$1,300/day x 2 days = \$2,600 for each system**

## 2) Dry Dock Maintenance: 1 S/E x 1 day for basic maintenance

- Initializing PC configuration
- Inspecting Servers, HDD, Fan, connections
- Checking workstation display value
- Function Test

- **Service Cost: \$1,300 for basic maintenance**
- **All the required spares to be supplied by owner**
- **The above estimation is an example only, and the actual cost shall be calculated**
- **Hotel & travel expenses to be added on actual basis**



**2.**

# **Engine Maintenance Service**

DF Engine, ME Engine, MC Engine, 4S Engine

## DF Engine Service

KGS service team are consist of ex-Hyundai or Wartsila Korea. Engineer are well trained as field service and abundant service work experiences(**All Korean engineers**). More than 30% cost effective than the original engine maker. KGS (KTS) registered to Hyundai Global Service(HGS) as the authorized repair agent. **Available for Wartsila DF & Hyundai HiMSEN DF engine**

### Estimation of major overhaul (18,000 R/H sample)

Engine type	Duration	Man-days	Estimation(USD)
12V50DF x 1	6 S/E X 20 Days	120	108,000
8L50DF x 1	6 S/E X 10 Days	60	54,000

**30% lower price  
than original maker**

- Estimation is based on major overhaul for 50DF engine (refer to KGS work scope)
- If require attached overhaul service(optional), 11~15 days by 6 S/E per engine
- Tariff: USD900 /man-day as lump-sum, **NO EXTRA COST FOR WEEKENDS & HOLIDAYS**
- All the required spares to be supplied by shipowner
- Estimation is for example only, actual cost shall be calculated as per condition
- Same work scope for major overhaul for 18,000 R/H or 24,000 R/H

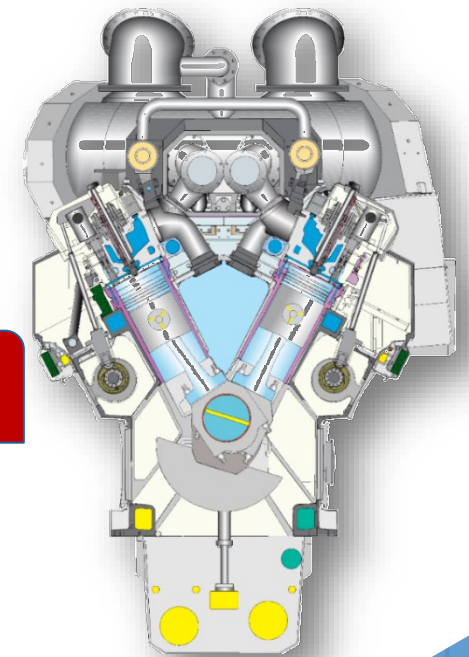

## DF Engine Major Overhaul (18,000 R/H)

**Connecting rods** : Inspect big/small end bearing for one bank, replace if required

**Crankshaft** : Inspect main bearing for one bank, replace if required

**Cylinder heads** : Replace with reconditioned one

**Cylinder liners** : Inspect liners and measure bore and honing, renew anti-polishing ring

**Piston** : Pull & inspect replace complete set of rings as running in program

## DF Engine Attached overhaul (Option)

**Booster servomotor for governor** : Overhaul and replace worn parts

**Exhaust manifold** : Renew expansion bellows

**Flexible coupling** : Check flexible coupling

**Fuel injection pump** : Overhaul and replace worn parts

**Governor driving gear** : Inspect and replace the parts

**HT-water pump** : Pump, driving gear, thermostatic valve, inspect and replace parts

**LT-water pump** : Pump, driving gear, thermostatic valve, inspect and replace parts

**Lube oil pump** : Pump, driving gear, thermostatic valve, inspect and renew bearing and shaft seal

**Main starting valve** : General overhaul and renew worn parts

**Pilot fuel pump** : Replace pilot fuel pump

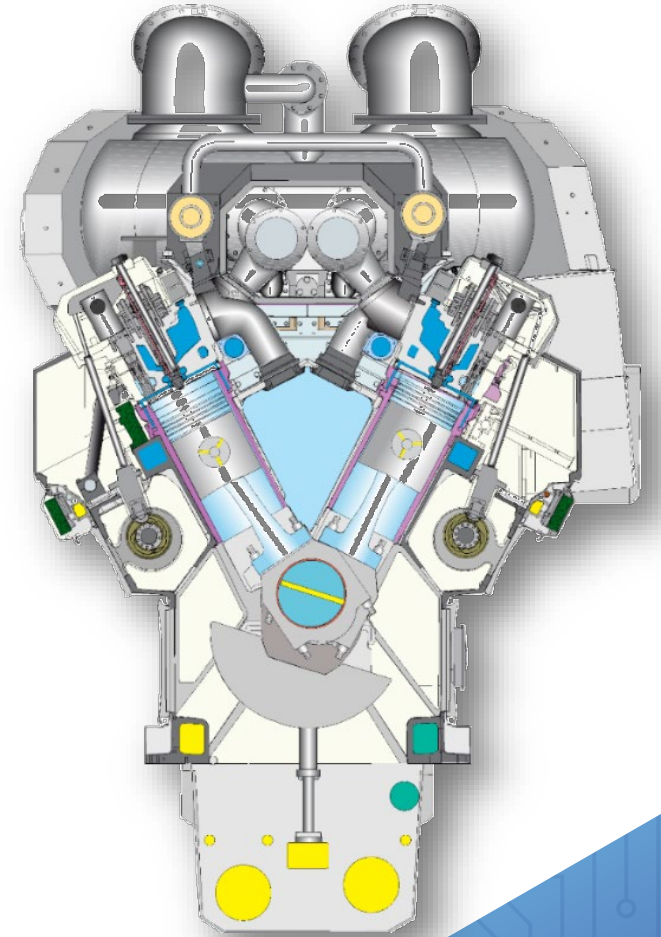



# ME Type Engine Service

According to MAN B&W's service letters ref: SL2017-643/SRJ & ref: SL2017-644/JERA of March 2017, we provide qualified service engineers, short delivery time of repair material & very competitive service price.

## 1) Work Scope

- ① Overhaul of fuel booster unit, exhaust actuator
- ② Overhaul of alpha lubricator, pneumatic system
- ③ Overhaul of FIVA valve, cleaning of proportional valve
- ④ Replacement of hydraulic hose (HCU, HPS)
- ⑤ Inspection of MPC, PSU, cabling
- ⑥ Calibration of HCU, HPS, Tacho system
- ⑦ Function test of Interlock, Hydraulic, Safety test

## 2) Service Work ( Actual days )

- ① Below 60ME : 2 S/E X 8 days + 2 Technician X 6 days
- ② Above 70ME : 2 S/E X 4 days + 3 Technician X 7 days

**25%~30% Lower price than original maker**



Action code: **WHEN CONVENIENT**

**Overhaul Strategy ME/ME-C and ME-B Engines**  
ME specific components

SL2017-644/JI  
March 2017

**Concerns**

Owners and operators of two-stroke marine diesel engines  
Type: ME/ME-

Action code: **WHEN CONVENIENT**

**Guiding Overhaul Intervals**  
Updated Tables

SL2017-643/SRJ  
March 2017

This Service Letter replaces SL2009-609/SBJ

**Concerns**

Owners and operators of MAN B&W two-stroke marine diesel engines.  
Type: ME-GI, ME/ME-C, ME-B and MC/MC-C.

**ONE S/E HANDLES MECHANICAL, ELECTRIC & CONTROL !**

# MC Type Engine Service

## Alpha Lubricator Maintenance (5 years, 10 years)

### 1) Work Scope

- Cylinder head overhaul
- Con-rod dis-assembling & maintenance
- Main bearing inspection ( 1 set only)
- Piston, liner dis-assembling & maintenance
- Timing gear, pump driving gear inspection
- Tappet, rocker arm check
- Camshaft bearing inspection
- Oil pump, water pump inspection
- Test trial

### 2) Service Work (Actual days)

- Below 60MC : 1 S/E X 4 days
- Above 70MC : 2 S/E X 3 days



**25%~30% Lower price than original maker**

## Pneumatic Control System Maintenance

### 1) Work Scope

- Inspection of control unit
- Timing check of angle encoder & pick up sensors
- Replacement of accumulators
- Inspection of feedback sensor
- Replacement of pump station kit
- Simulation test by pre-lubrication

### 2) Service Work (Actual days)

- Below 60MC : 2 S/E X 3 days
- Above 70MC : 2 S/E X 4 days

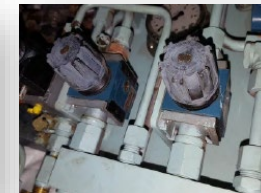

## 4 Stroke Engine Maintenance (MAN, Hyundai HiMSEN)

### 1) Work Scope

- Cylinder head overhaul
- Con-rod dis-assembling & maintenance
- Main bearing inspection ( 1 set only)
- Piston, liner dis-assembling & maintenance
- Timing gear, pump driving gear inspection
- Tappet, rocker arm check
- Camshaft bearing inspection
- Oil pump, water pump inspection
- Test trial

### 2) Service Work ( Actual days, 6 cylinder case )

- H17/28 & H21/32: 3 S/E X 7 days, 1 S/E X 9 days ( 3 crews help)
- H25/33 & H32/40: 3 S/E X 8 days, 1 S/E X 11 days ( 3 crews help)

**25%~30% Lower price than original maker**





# 3. Other Service

Engine Part Reconditioning, Boiler, Hyd. System

# Main Engine Part Reconditioning

KGS has been providing reconditioning of 2 & 4 stroke engine components at Korean ports. The workshop is duly certified by MDT & Wartsila for various re-conditioning work, and we are proud to provide the service as competitive price and good quality.

## 1) Reconditioning /Overhaul /Repair

- Cylinder Cover/Head
- Exhaust V/V spindle & Bottom piece
- Piston crown, Rod, Skirt

**Piston Crown Recondition : USD 8,000~9,000**

- Including Ni-Alloy welding/machining on combustion surface

## 2) Chrome Plating

- Ring groove for piston crown
- Stem part for exhaust V/V spindle

**Exh. Valve Spindle Recondition : USD 4,000~5,000**

- Including Inconel cladding on combustion surface

**25%~30%  
Lower price  
than original  
maker**

## 3) Other reconditioning parts

- FIVA Valve(replacing proportional valve & inductive sensor)
- F.O Parts (Plunger & Barrel, Spindle guide, Nozzle and etc.)

# Kangrim Boiler & IGG

KGS promises Reliable, Remarkable and Rapid service for your firing plant with competitive price through our service company.

## 1) Service

- ① KANGRIM boiler: D/D maintenance work & system re-commissioning  
→ Sunflame burner, Volcano burner, Hamworthy burner.
- ② KANGRIM IGG, IGS maintenance work
- ③ KANGRIM incinerator service

## 2) Qualified service with competitive Price

Normal Rate
<b>\$1,600/man</b> 8hrs + 4hrs O/T

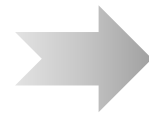

KGS Provides
<b>\$900/man</b> 8hrs + 4hrs O/T

**43%  
Down**



*\*All service engineers have work experiences in the original manufacture for more than 15 years!*

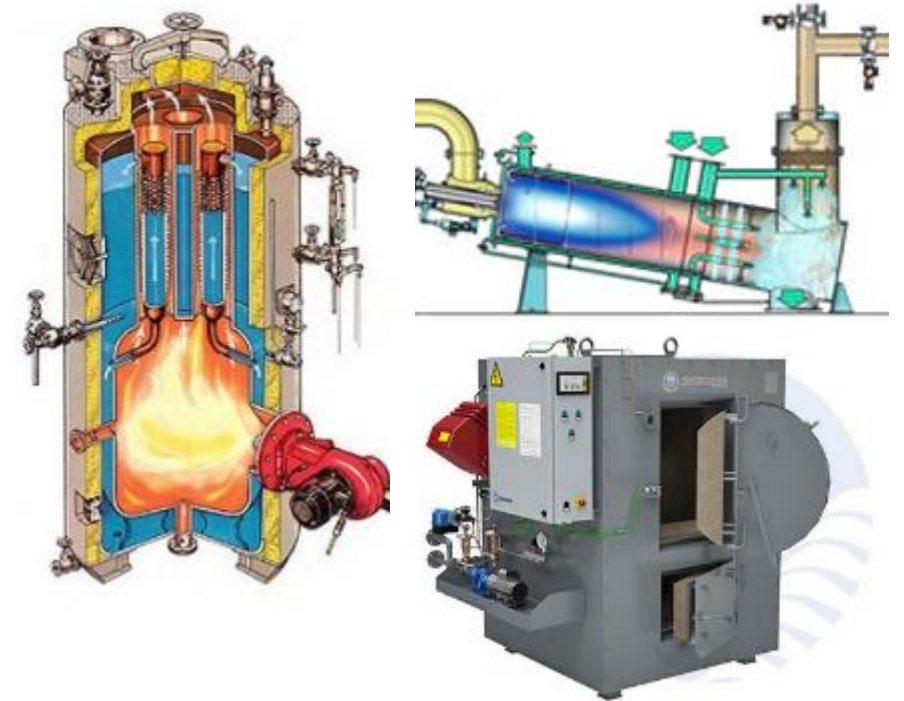

## 3) Other services available

- ① Commissioning & Installation
- ② Trouble-Shooting services
- ③ Spare parts (OEM)



# Hydraulic System (Deck Machinery, Crane)

KGS can provide service & spares for Hydraulic equipment, such as deck machinery, deck cranes and hatch covers with competitive price. All of engineers has long-term experience from original makers, Pusnes, MacGregor, Oriental.

1. Maintenance, Repair and installation
2. General inspection, Pre-docking inspection
3. Winch/Windlass performance test
4. Reconditioning of hydraulic motor/pump
5. Crew training for hydraulic equipment

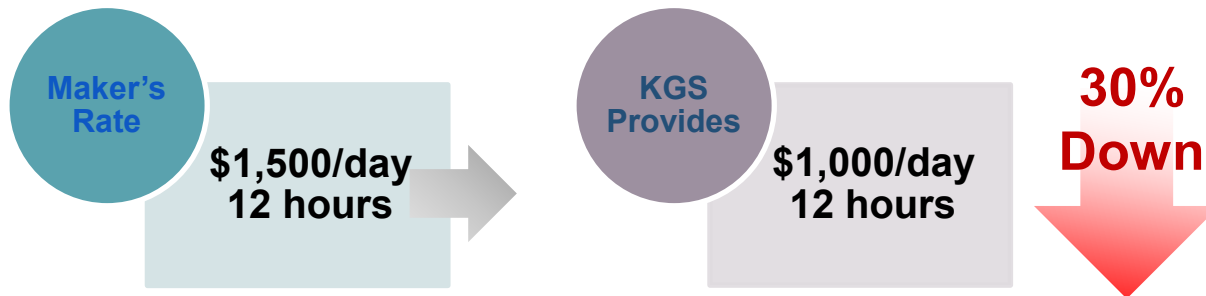



**KOREA PROFESSIONAL MAINTENANCE PROVIDER**  
KOREA GLOBAL SERVICE  
 1000-010-01000000  
 1000-010-01000000  
 1000-010-01000000  
 1000-010-01000000  
 1000-010-01000000

**SERVICE REPORT**



Ship Name	Marek Sazabi	Date of report	2018 Mar. 14
Place	Zoukou Cruise Shipyard, China	Reported by	
Customer	Marek Singapore	Work period	1803.13-15
Subject	Marek Sazabi Dry Dock Maintenance	Reference No.	

As requested by the shipowner of Marek Singapore, Korea Global Service team attended the maintenance work for checking and supervising of the ship's deck machinery including the maintenance of parts and parts during maintenance work at Zoukou Cruise Shipyard in China from March 12 to March 15, 2018.



All working which and condition was carried out operating test in previous part of On-docking.  
 S. Korea with good condition except maintenance for 100.  
 All related cases for maintenance and inspection were well carried out according to following sub-paragraphs options.

**1. WHIPORT Winch**



- 1) Brake lining for anchor was removed by shipyard on 13 Mar. 2018.
- 2) Top cover and bottom plate maintenance.
- 3) Lubricated parts are to be renewed.

Lubricated parts, top cover  
 Broken lining for anchor was removed. After removing the broken lining, Brake stopper ball to be renewed and adjusted 1 mm to 1.5 mm.

Brake lining for anchor was removed by shipyard on 13 Mar. 2018.  
 Brake lining for anchor was removed and cleaned and installed to make free.  
 For Brake lining was worked well.  
 Brake lining for anchor was to be renewed. After removing the broken lining, Brake stopper ball to be renewed and adjusted around 1 mm to 1.5 mm.  
 Line about anchor stopper ball can be adjusted after brake lining completely.

Broken for hook bracket of anchor Brake Stopper was renewed and adjusted and  
 bracket can be renewed.

## General Repair Service

1. Coverage : Korea, China, Singapore
2. Repair Net-work : Hyundai cooperative repair companies
3. Major work
  - Hull repairs
  - Hull outfitting & piping
  - Machinery
  - Electric Equipment
  - Under water repair
  - Tank Cleaning
  - Safety Equipment Service (Korea)
    - Life boat, Life raft
    - Fire fighting appliances
    - Radio Survey



4.

# Home Port Service

One Stop Total Maintenance Service in Korean Ports

# Korea – Consolidated Services in all Korean Ports

1. Electric service – Qualified service by Ex-Hyundai commissioning & Ex-Original engineer
2. Engine service – Certified/cooperated engine service team & qualified re-conditioning workshop

## ELECTRIC SERVICE

- SWBD trouble shooting
- Safety Test (M/E, G/E, Boiler, etc)
- Modification Panel, Cabling work
- UPS, Battery Charger, Signal Column
- Nabtesco, BMS, Governor Overhaul
- Aconis, Kongsberg AMS, PMS, BNWAS
- Panel Thermographic survey
- ACB Retrofit

## NAV. & RADIO SERVICE

- GMDSS, VDR Annual survey
- Auto Pilot survey
- Gyro compass Annual maintenance for all maker (Yokogawa, Tokimec, C. Plath)
- Radio annual survey

## KOREAN MAKER SERVICE

- Kangring boiler, IGG
- Samgong purifier – bowl reconditioning
- Pusnes deck machinery, hydraulic SVC
- Hyundai Cargo oil pump, turbine
- Hyundai Side Thruster trouble shooting

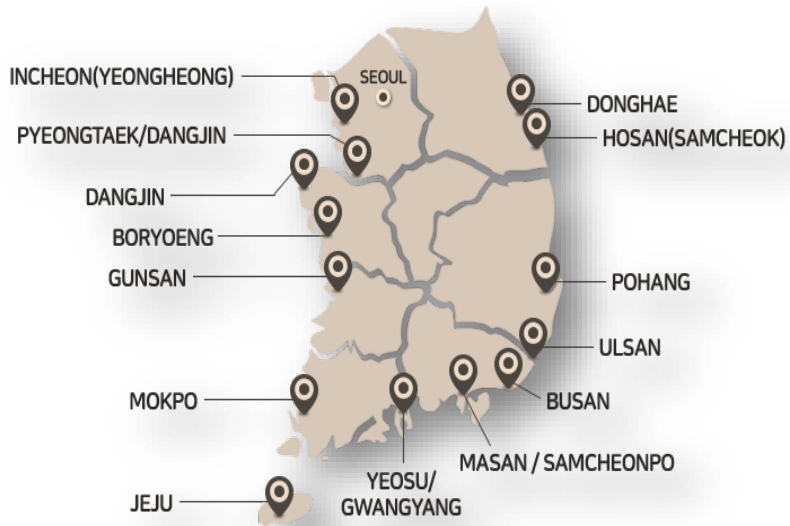

## MAIN ENGINE SERVICE

- M/E type engine trouble shooting including electric problem
- Overhauling work
- RT\_Flex engine maintenance
- M/E spare reconditioning (Cyl. Cover/Head, Crown, Exh V/V)

## 4 STROKE ENGINE SERVICE

- STX, MAN, Hyundai
- Overhaul service
- Cylinder head, Con-rod, Main bearing
- Camshaft bearing, oil pump

## SPARE SUPPLY

- Hyundai pump, turbine
- Hyundai SWBD electric part
- M/E, D/G engine spares
- Korean maker spares

## GENERAL REPAIR

- Hull Repair
- Hull Outfitting & Piping
- Tank Cleaning
- Other machinery

## SAFETY EQUIPMENT

- Survey of Life raft, Life boat davit
- Load test davit, crane (E/R, provision) & other lifting appliances, Ladder
- Sales for fire fighting equipment